

# MCS

DYEING & FINISHING MACHINERY

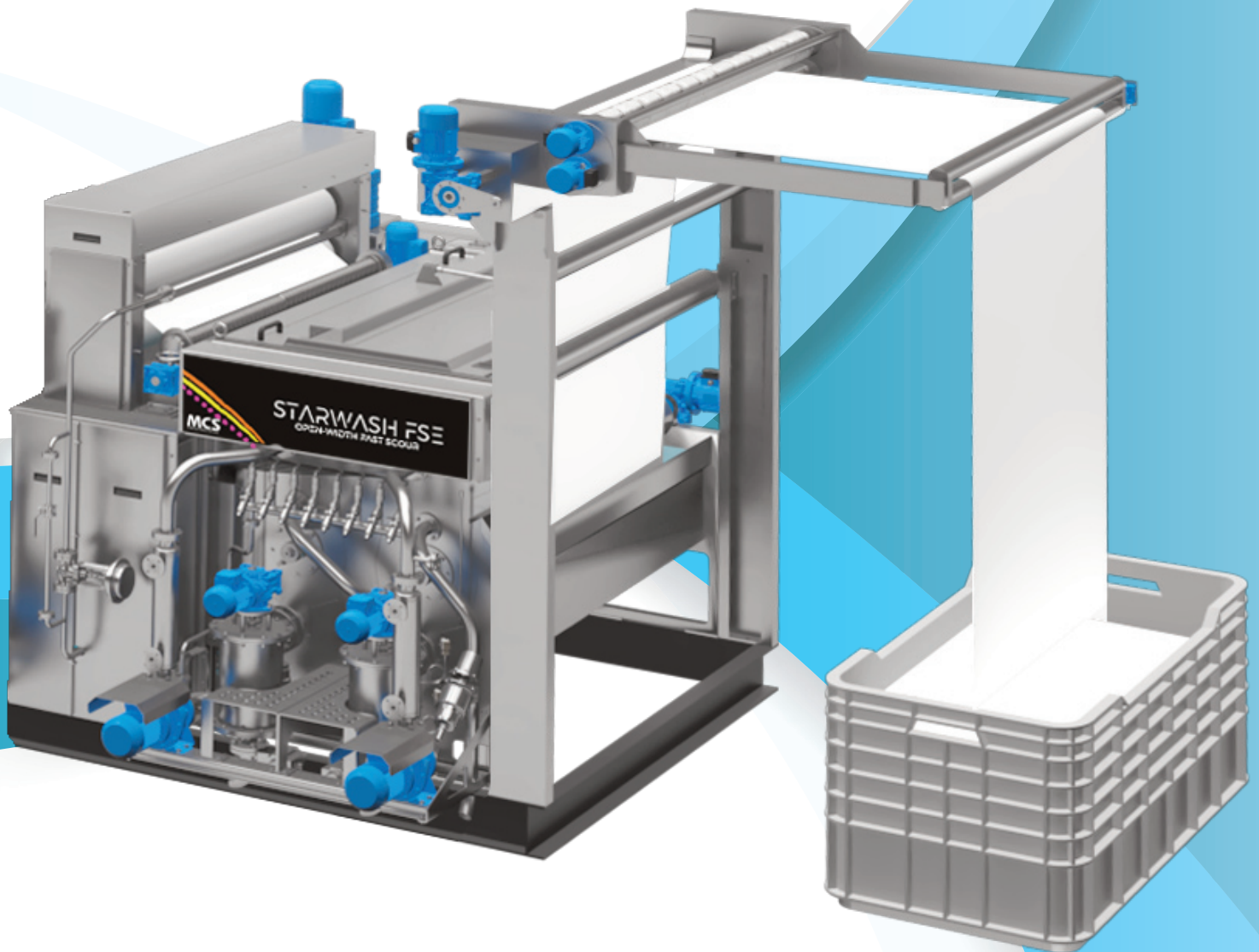

# STARWASH FS EVO

OPEN-WIDTH TENSION-LESS SCOURING BOX



# OUR HISTORY

DYEING & FINISHING MACHINERY

**MCS**

MCS & TERMO INNOVATION ZONE

**BLUE**  
AREA

COMMISSION ECO-DYEHOUSE

**EUROPIZZI**

AUTOMATION & SOFTWARE

**Termo**  
elettronica



**mcsgroup.it**  
Bergamo - Italy

member of  
**ACIAIT**  
ITALIAN TEXTILE MACHINERY

MCS spa, since 1963, develops, manufactures and installs discontinuous dyeing machines and washing & preparation lines

## 2023 ITMA - Milan

MCS exhibits:

- Multiwash-M,
- Comby Jigger-C4,
- Chronoflow,
- Softflow-18

## 2019 ITMA - Barcellona

MCS exhibits:

- Lavaprint Next,
- Dynamica Sprint,
- Mini Jigger 98,

MCS presents:

- C4 Comby Jigger 143;
- Softflow 18-HT.

## 2017

MCS presents:

- Mini Jigger 98.

## 2015 ITMA - Milan

MCS exhibits:

- Multiwash,
- Dynamica Sprint,
- Starwash FS,
- Termopowder XP,
- Texmanager XP,
- Termochem XP.

## 2014 ITMA - Shanghai

MCS exhibits:

- Starwash Fast Scouring.

## 2013

MCS celebrate their 50 th anniversary

## 2011 ITMA - Barcellona

MCS exhibits:

- Dynamica,
- Star Wash,
- Comby Jigger,
- Supervisor Texmanager.

## 2009

MCS presents:

- Italica.

## 2008

MCS Re-design of all high and low temperature Jigger models.

## 2007 ITMA - Munich

MCS exhibits:

- Universal Dyeing,
- First Vento,
- Tumbler Mistral,
- VDA.

## 2005 IKME - Milan

MCS exhibits:

- Universal Dyeng, VDA.

## 2003 ITMA - Birmingham

MCS exhibits:

- Multiflow Superior,
- Ecoturbo Beam Dyeing Machine.

## 2000

MCS acquires 100% of Ter-moelettronica owner-ship.

## 1999 ITMA - Paris

MCS exhibits:

- Multiflow,
- Softflow 100 Evolution,
- Comby jigger electronic.

## 1995 ITMA - Milan

MCS exhibits:

- Softflow,
- Long Horn,
- Pumex

## 1991 ITMA - Hannover

MCS exhibits:

- Tornado Tumbler,
- Maxi & Mid jiggers,
- Lavaprint.

## 1987 ITMA - Paris

MCS exhibits: Pandora.

## 1983 ITMA - Milan

MCS exhibits:

- Tubular mercerizer MT26,
- Softflow-82 LT/HT,
- Flow/jet OF83,
- Comby Jigger HT,
- WR rope washing machine.

## 1980

Europea activity begins, group dyeing and resining company.

## 1979 ITMA - Hannover

MCS exhibits:

- Jet HT,
- Overflow MO/80 LT,
- MRS65.

## 1974

MCS begins the design and development of the open width lines.

## 1971 ITMA - Paris

MCS exhibits:

MCS exhibits the first low temperature jet model.

## 1968

Europizzi begins its activity

## 1967

MCS manufactures the first low temperature rope dyeing machine.

## 1964

MCS begins its activity.

## 1963

Gino Chiappini, Angelo Cagnazzo, founding MCS. Gino Chiappini is the Chairman of the Board.



# STARWASH FS EVO

## OPEN-WIDTH TENSION-LESS BOX SCOURING

**STARWASH FAST SCOUR EVO** è pensata per purgare in continuo al termofissaggio, allo scopo di ridurre la quantità di olio presente nei tessuti elasticizzati e prepararli al meglio per le successive fasi di lavorazione. Gli oli da eliminare principalmente sono i siliconi provenienti dagli elastomeri e i minerali utilizzati come lubrificanti in tessitura.

Questi oli, bruciando con le alte temperature del termofissaggio, si eliminano in maniera disuniforme e creano zone di diverso assorbimento all'interno del tessuto.

Ridurre e uniformare questi oli sulla superficie del tessuto diventa quindi una operazione fondamentale, da fare prima del trattamento termico. Un tessuto già termofissato e purgato in discontinuo su una macchina di tintura avrà caratteristiche qualitative inferiori, oltre che un costo di lavorazione più alto.

**Starwash FS EVO** è interamente ingegnerizzata e costruita in MCS.

Ogni nuovo modello viene testato ed esposto, in INNOVATIVE BLUE AREA integrato nella tintoria del gruppo MCS.

**STARWASH FAST SCOUR EVO** has been designed for scouring in continuous with heatsetting, in order to reduce the quantity of oil present in elastic fabrics and to prepare the fabrics to subsequent processings.

Oils to be eliminated are mainly silicones coming from elastomers and minerals used as lubricants in weaving. Such oils, burning at high temperatures during heatsetting, are eliminated unevenly and create areas with different absorptions inside the fabric itself.

Reduce and make these oils even on the surface of the fabrics becomes a fundamental operation to be carried out before heat-setting. Heat-set fabrics, scoured in a discontinuous machine will have inferior qualities, as well as more expensive processing costs.

**Starwash FS EVO** is entirely engineered and built in MCS.

Each new model is tested and exhibited, in INNOVATIVE BLUE AREA integrated in the MCS Group dyeing plant.



### STORIA DELLE LINEE IN CONTINUO MCS

**1974 MCS** inizia la progettazione e lo sviluppo delle linee di lavaggio.

**1983 ITMA - Milano:** MCS espone la prima gamma per il lavaggio in corda WR

**1991 ITMA - Hannover:** MCS espone la prima gamma di lavaggi combinati LAVAPRINT

**2011 ITMA - Barcellona:** MCS espone la gamma di lavaggio a tamburo STARWASH

**2015 ITMA - Milano:** MCS espone la prima gamma di lavaggi in corda compatti MULTIWASH e STARWASH FAST SCOUR

**2019 ITMA - Barcellona:** MCS presenta STARWASH-EVO

**2023 ITMA - Milano:** MCS presenta MULTIWASH-M

### HISTORY OF CONTINUOUS LINES MCS

**1974: MCS** begins the design and development of the open-width lines.

**1983 ITMA - Milan:** MCS exhibits the first rope washing range WR

**1991 ITMA - Hannover:** MCS exhibits the first combined washing range LAVAPRINT

**2011 ITMA - Barcelona:** MCS exhibits the drum washing range STARWASH

**2015 ITMA - Milan:** MCS exhibits the first compact washing range MULTIWASH and STARWASH FAST SCOUR

**2019 ITMA - Barcelona:** MCS exhibits the STARWASH-EVO

**2023 ITMA - Milan:** MCS exhibits the first modular washing range MULTIWASH-M

# STARWASH FS EVO

## OPEN-WIDTH TENSION-LESS SCOURING BOX

**STARWASH FAST SCOUR EVO (FS EVO)** è il l'innovativo box di purga MCS, ideale per fibre sintetiche e naturali anche ad elevato contenuto elastomerico. Modulare e compatto permette di processare, tessuti sia a maglia che a trama-catena, grazie al sistema brevettato sistema OVERFLOW & BUBBLE SYSTEM.

**STARWASH FAST SCOUR EVO (FS EVO)** is the innovative scouring box by MCS, ideal for synthetic and natural fibers with high percentage of Lycra. Modular and compact, it allows to process knitted and woven articles as well thanks to patented OVERFLOW & BUBBLE SYSTEM.

# Elimination Oil to protect the environment

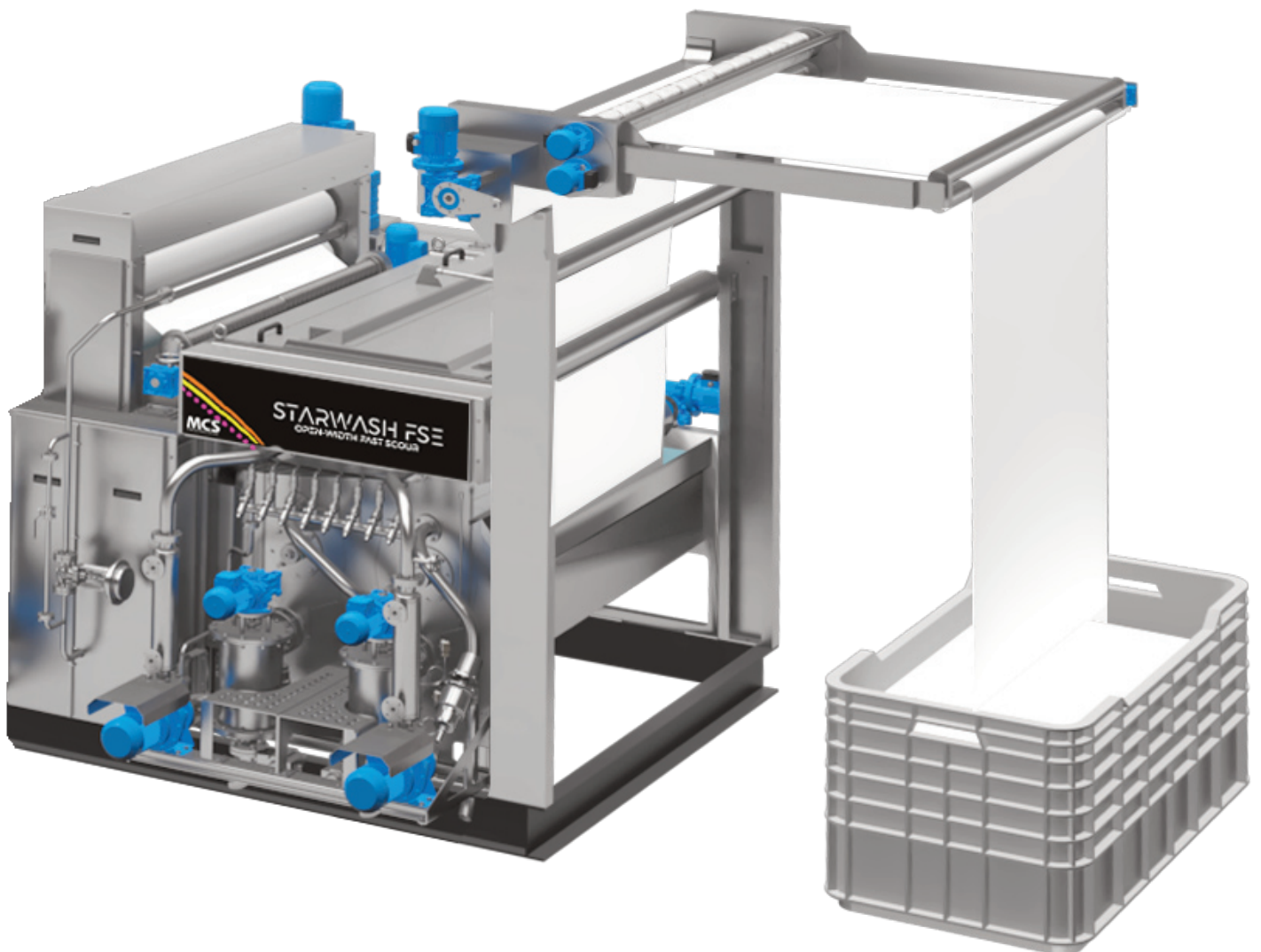

# TECHNICAL DATA

Il trasporto del tessuto avviene attraverso due tamburi motorizzati interni di grosse dimensioni, tre cilindri di rinvio sui quali sono montate delle celle di carico ed un foulard di spremitura.

Il ricircolo interno del bagno forzato di lavaggio e la presenza di spruzzatori, permettono al tempo stesso un grande impatto lavante, una estrema delicatezza sulle fibre più sensibili e la completa eliminazione dei detersivi usati nel processo di purga. Gli oli residui vengono eliminati grazie ad uno speciale filtro.

*Fabric runs thanks to two big-size driven drums, three transmission rollers on which load-cells are installed, and then a squeezer.*

*Inner circulation of forced liquor and sprayers guarantee a remarkable washing impact and, at the same time, an extremely delicate action on more sensitive fibres and complete removal of detergents used during scouring process. Removed oils are eliminated by means of a special filter.*

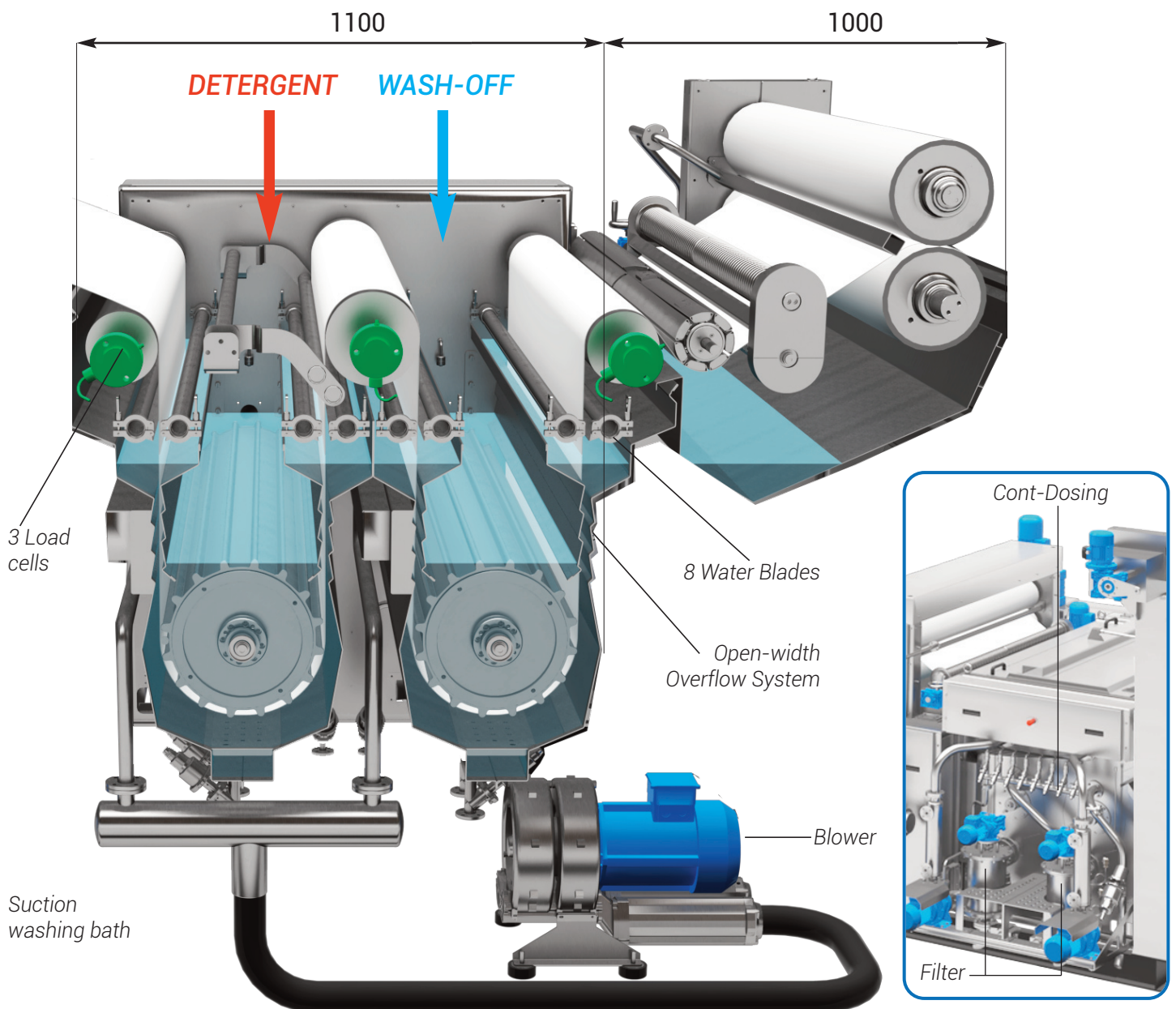

# LAYOUT EXAMPLES

## SOLUTION 1

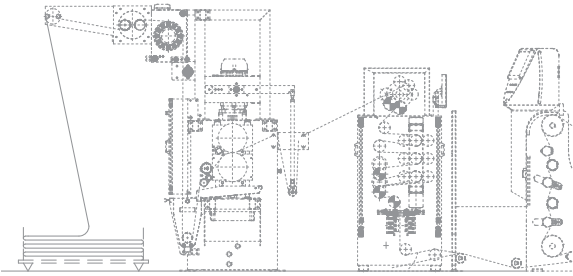

Original Customer Configuration

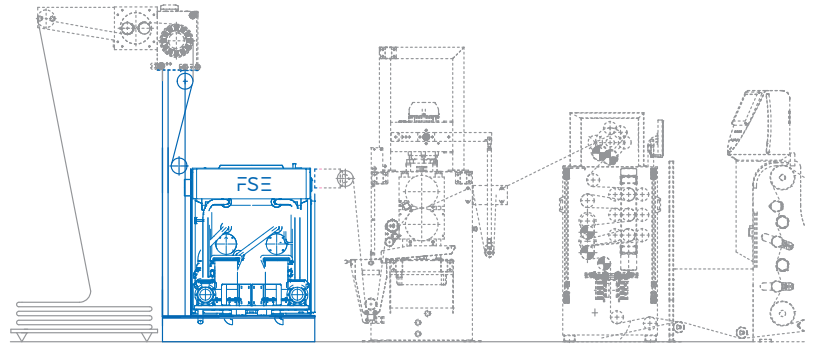

MCS Suggest: Only Starwash FS EVO

## SOLUTION 2

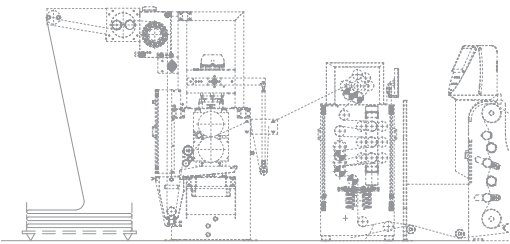

Original Customer Configuration

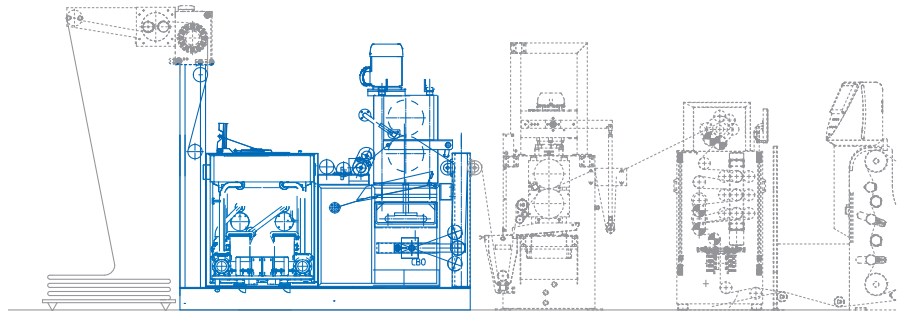

MCS Suggest: Starwash FS EVO + Expanders + 10 tons Squeezer

## SOLUTION 3

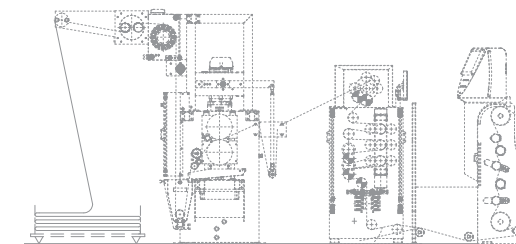

Original Customer Configuration

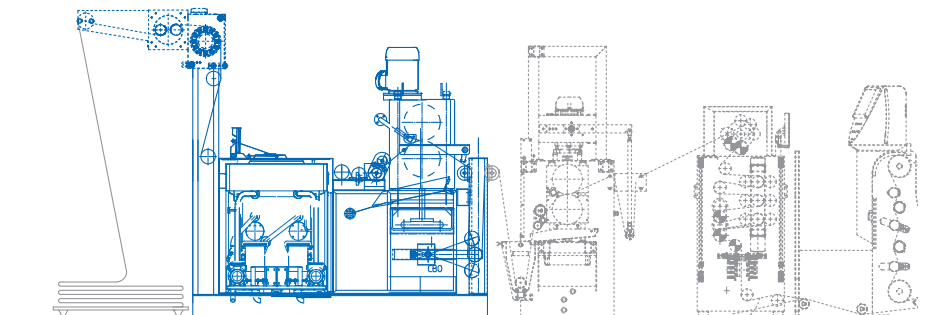

MCS Suggest: Fabric width dogal inlet + Starwash FS EVO + Expanders + 10 tons Squeezer

## CTRL-WASH operation panel

CTRL-WASH next gen Windows 10 IOT con schermo touch screen capacitivo e nuovo software di controllo TECOP il quale presenta un'interfaccia grafica interamente ridisegnata con sinottico dinamico in grafica vettoriale.

CTRL-WASH next gen windows 10 IOT with capacitive touch screen and new automation software TECOP bringing a completely new graphical interface, dynamic synoptic and vectorial graphics.

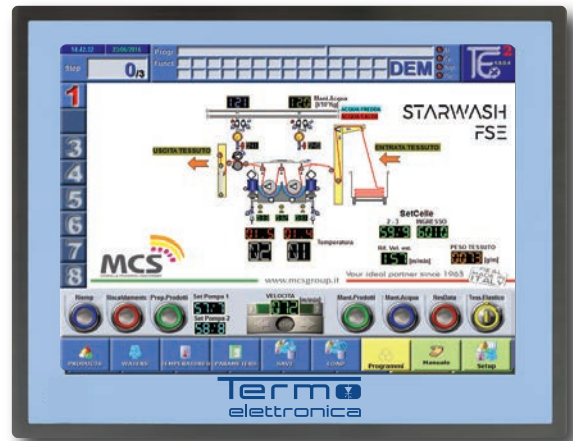

## CONT-DOSING Dosing of pure products and water control in a washing line

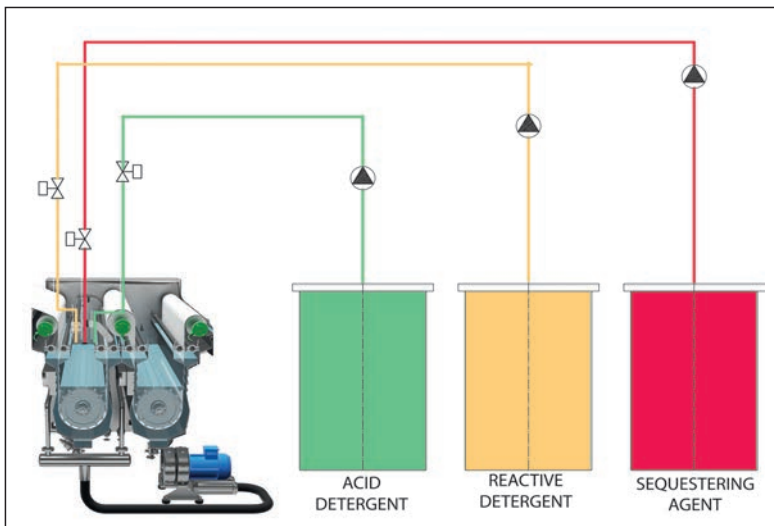

Il sistema CONT-DOSING è un sistema gestito da un PC in comunicazione con un PLC; può comandare fino a 8 pompe dosatrici e controllare fino a 8 ingressi d'acqua. Le pompe dosatrici usate sono a pistone pneumatico a doppio effetto: la frequenza di comando è calcolata in modo da evitare repentine e variazioni della concentrazione del bagno.

*The CONT-DOSING system is a system managed by a PC communicating with a PLC which can control up to 8 dosing pumps and 8 water inlets.*

*Installed dosing pumps are with pneumatic piston at double effect. Pump control frequency values are calculated so as to avoid sudden changes in the concentration of the bath.*

## TEX-LINE 4.0 Software integrated for washing lines

- > Gestione parametrizzazioni linea
- > Gestione delle pianificazioni
- > Controllo real time dati macchina
- > Database degli articoli

- > Parametrization Handling
- > Batches Handling
- > Real time machines supervising
- > Fabrics database

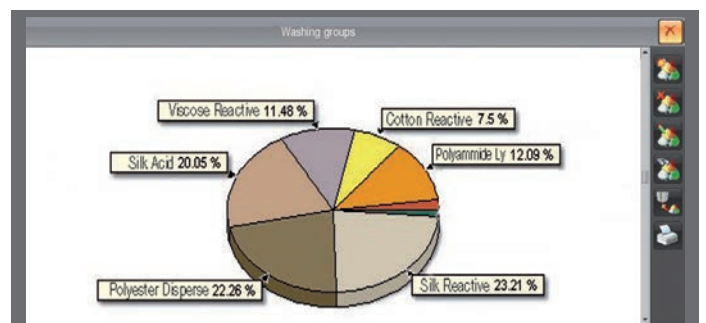

# FEEL THE POWER OF WATER

DYEING & FINISHING MACHINERY



**MCS**

Bergamo | Italy | mcstextile.it



THINK BEFORE YOU PRINT