

MCS

DYEING & FINISHING MACHINERY



STARWASH-EVO

OPEN-WIDTH WASHING RANGE



OUR HISTORY

DYEING & FINISHING MACHINERY

MCS

MCS & TERMO INNOVATION ZONE

BLUE
AREA

COMMISSION ECO-DYEHOUSE

EUROPIZZI

AUTOMATION & SOFTWARE

Termo
elettronica



mcsgroup.it
Bergamo - Italy

member of
ACIAIT
ITALIAN TEXTILE MACHINERY

MCS spa, since 1963, develops, manufactures and installs discontinuous dyeing machines and washing & preparation lines

2023 ITMA - Milan

MCS exhibits:

- Multiwash-M,
- Comby Jigger-C4,
- Chronoflow,
- Softflow-18

2019 ITMA - Barcellona

MCS exhibits:

- Lavaprint Next,
- Dynamica Sprint,
- Mini Jigger 98,

MCS presents:

- C4 Comby Jigger 143;
- Softflow 18-HT.

2017

MCS presents:

- Mini Jigger 98.

2015 ITMA - Milan

MCS exhibits:

- Multiwash,
- Dynamica Sprint,
- Starwash FS,
- Termpowder XP,
- Texmanager XP,
- Termochem XP.

2014 ITMA - Shanghai

MCS exhibits:

- Starwash Fast Scouring.

2013

MCS celebrate their 50 th anniversary

2011 ITMA - Barcellona

MCS exhibits:

- Dynamica,
- Star Wash,
- Comby Jigger,
- Supervisor Texmanager.

2009

MCS presents:

- Italica.

2008

MCS Re-design of all high and low temperature Jigger models.

2007 ITMA - Munich

MCS exhibits:

- Universal Dyeing,
- First Vento,
- Tumbler Mistral,
- VDA.

2005 IKME - Milan

MCS exhibits:

- Universal Dyeng, VDA.

2003 ITMA - Birmingham

MCS exhibits:

- Multiflow Superior,
- Ecoturbo Beam Dyeing Machine.

2000

MCS acquires 100% of Termoelettronica ownership.

1999 ITMA - Paris

MCS exhibits:

- Multiflow,
- Softflow 100 Evolution,
- Comby jigger electronic.

1995 ITMA - Milan

MCS exhibits:

- Softflow,
- Long Horn,
- Pumex

1991 ITMA - Hannover

MCS exhibits:

- Tornado Tumbler,
- Maxi & Mid jiggers,
- Lavaprint.

1987 ITMA - Paris

MCS exhibits: Pandora.

1983 ITMA - Milan

MCS exhibits:

- Tubular mercerizer MT26,
- Softflow-82 LT/HT,
- Flow/jet OF83,
- Comby Jigger HT,
- WR rope washing machine.

1980

Europea activity begins, group dyeing and resining company.

1979 ITMA - Hannover

MCS exhibits:

- Jet HT,
- Overflow MO/80 LT,
- MRS65.

1974

MCS begins the design and development of the open width lines.

1971 ITMA - Paris

MCS exhibits:

MCS exhibits the first low temperature jet model.

1968

Europizzi begins its activity

1967

MCS manufactures the first low temperature rope dyeing machine.

1964

MCS begins its activity.

1963

Gino Chiappini, Angelo Cagnazzo, founding MCS. Gino Chiappini is the Chairman of the Board.



STARWASH-EVO

OPEN-WIDTH & TENSION-LESS WASHING RANGE

Starwash-Evo è l'innovativo box di lavaggio in largo MCS.

Modulare e compatto permette di processare, tessuti sia a maglia che a trama-catena, grazie al sistema brevettato: OVERFLOW & BUBBLE SYSTEM

Il trasporto del tessuto avviene attraverso due grandi tamburi motorizzati interni di grosse dimensioni, tre cilindri di rinvio sui quali sono montate delle celle di carico ed un foulard di spremitura.

Il ricircolo interno del bagno forzato di lavaggio e una lama d'acqua orientabile sul tessuto, permettono al tempo stesso un grande impatto lavante ed una delicatezza sulle fibre più sensibili.

Ogni box di lavaggio è dotato di una soffiante ad aria: grazie a questo sistema si aumenta la turbolenza dell'acqua e quindi la capacità lavante dalla stessa.

È un lavaggio ideale per fibre sia sintetiche che naturali, sia per lavaggi dopo stampa tradizionale che ink-jet, per lavaggi e fissazione della lana, oppure per lavaggi dopo candeggio e/o mercerizzo.

Starwash-Evo is the innovative MCS new open-width washing line.

Modular and compact, it allows to process both knitted and woven fabrics, thanks to the patented: OVERFLOW & BUBBLE SYSTEM.

The fabric is transported through two large internal driven drums, three transmission cylinders on which load cells are installed and a squeezing padder.

The internal recirculation of the forced washing liquor and an adjustable water blade on the fabric, allow a great washing impact and a delicate action on most sensitive fibers, at the same time.

Each washing box is equipped with an air blower: thanks to this system the turbulence of the water is increased and therefore the washing efficiency as well.

It is the ideal washing solution for both synthetic and natural fibers; for washing after traditional printing and ink-jet printing as well; for washing and fixing wool or for washing after bleaching and/or mercerizing.



STORIA DELLE LINEE IN CONTINUO MCS

1974 MCS inizia la progettazione e lo sviluppo delle nostre linee in continuo.

1983 ITMA - Milano: MCS espone la prima gamma per il lavaggio in corda WR

1991 ITMA - Hannover: MCS espone la prima gamma di lavaggi combinati LAVAPRINT

2011 ITMA - Barcellona: MCS espone la gamma di lavaggio a tamburo STARWASH

2015 ITMA - Milano: MCS espone la prima gamma di lavaggi in corda compatti MULTIWASH

2019 ITMA - Barcellona: MCS presenta STARWASH-EVO

2023 ITMA - Milano: MCS presenta MULTIWASH-M

HISTORY OF CONTINUOUS LINES MCS

1974: MCS begins the design and development of our continuous lines.

1983 ITMA - Milan: MCS exhibits the first rope washing range WR

1991 ITMA - Hannover: MCS exhibits the first combined washing range LAVAPRINT

2011 ITMA - Barcelona: MCS exhibits the drum washing range STARWASH

2015 ITMA - Milan: MCS exhibits the first compact washing range MULTIWASH

2019 ITMA - Barcelona: MCS exhibits the STARWASH-EVO

2023 ITMA - Milan: MCS exhibits the first modular washing range MULTIWASH-M

STARWASH-EVO

OPEN-WIDTH & TENSION-LESS WASHING RANGE

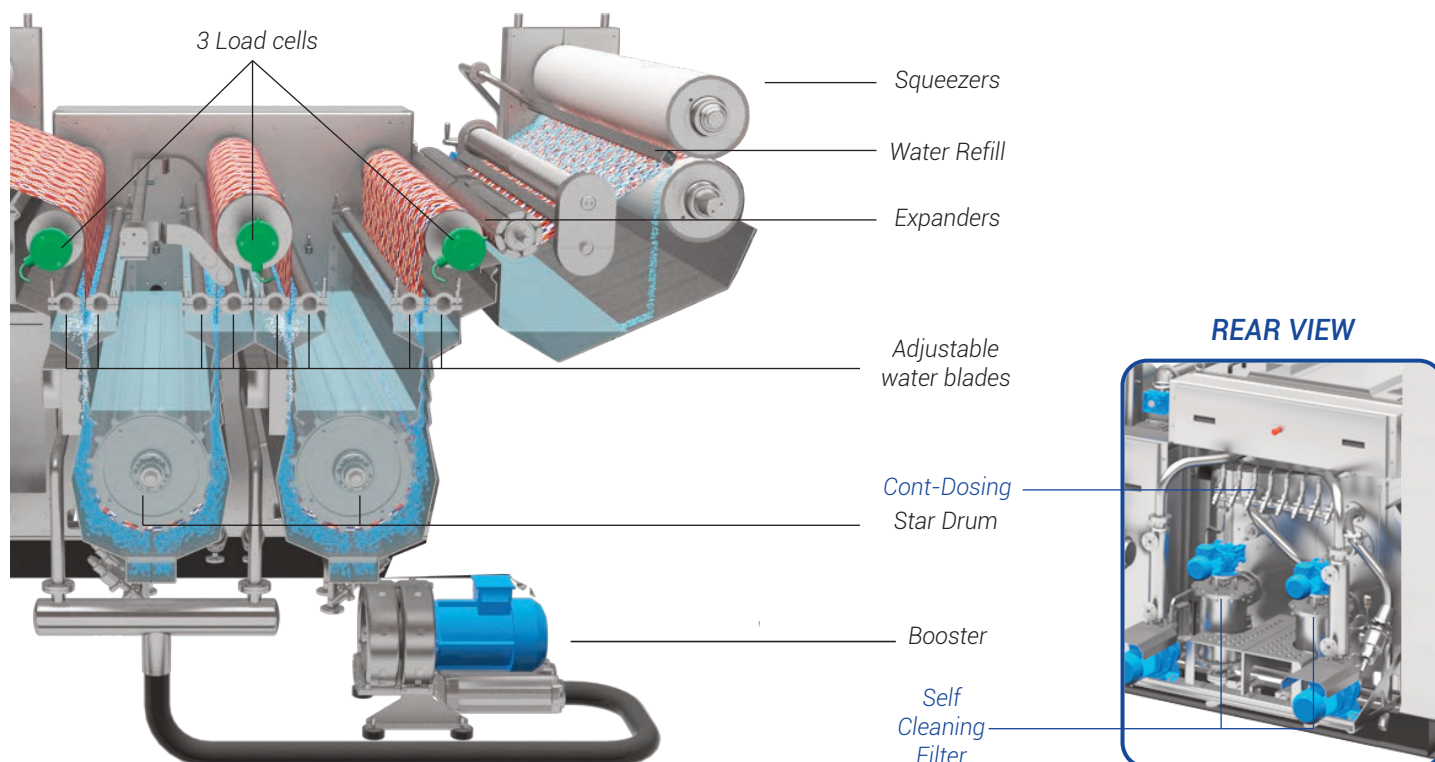

Il disegno sagomato delle vasche e l'elevato numero di riciccoli/reintegri di acqua pulita consentono di ottenere una maggiore penetrazione del bagno nella fibra.

Il processo viene amplificato dall'azione della soffiante, che determina un lavaggio più efficace con consumi ridottissimi.

L'innovativo sistema di recupero delle acque di lavaggio, permette un notevole risparmio energetico contribuendo alla riduzioni delle emissioni di gas in atmosfera.

The shaped design of the tanks and the high number of clean water recirculation/reintegration processes allow for greater penetration of the bath into the fiber.

The process is simplified by the action of the blower, which determines a more effective washing with minimized consumption.

The innovative system for the recovery of washing liquor allows remarkable water saving thus contributing to the reduction of gas emissions in the air

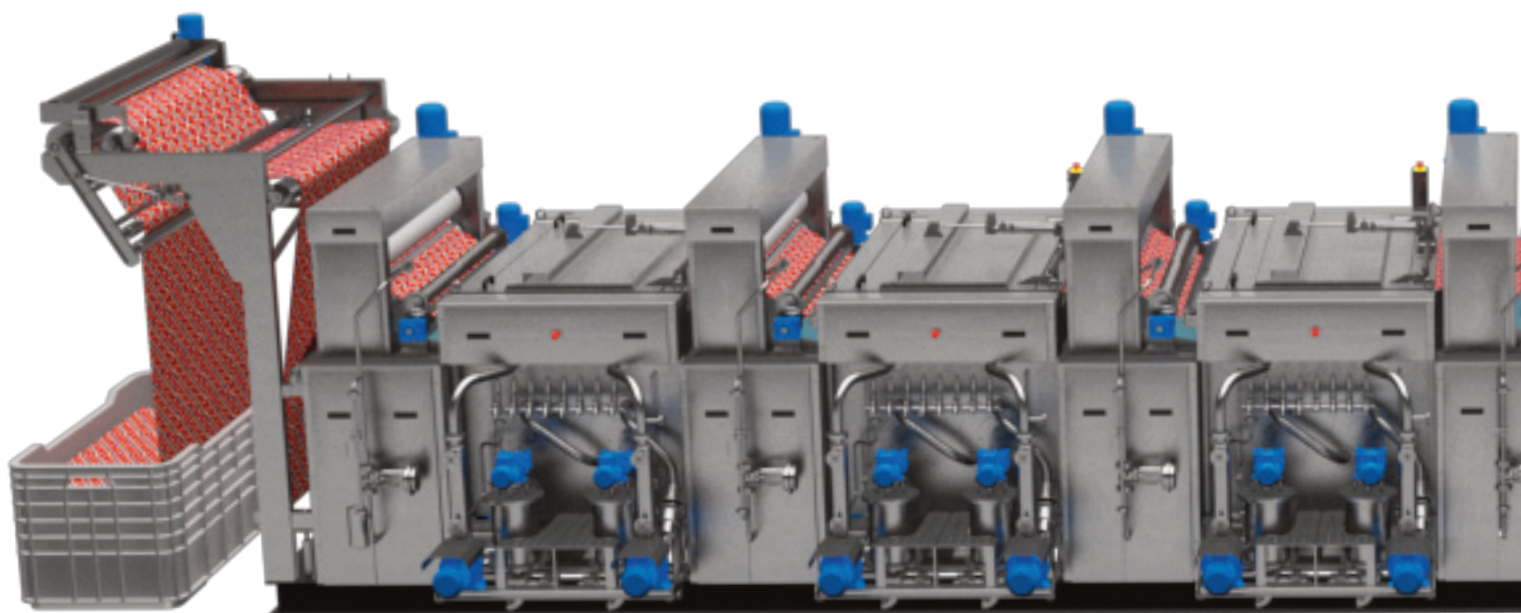

STARWASH-EVO

OPEN-WIDTH & TENSION-LESS WASHING RANGE

- Circolazione del bagno in controcorrente forzata
 - Tamburi di lavaggio a grande efficienza a forma stellare
 - Sistema di rigenerazione dell'acqua
 - Aria canalizzata in ogni singolo box di lavaggio
 - Sistema filtraggio esterno autopulente, idoneo per ogni tipo di fibra e lavorazione
 - Accesso per manutenzione ordinaria semplificata
 - Gestione remota intelligente integrata (4.0)
 - Raccolta realtime dei dati macchina su cloud per elaborazione e manutenzione preventiva
 - Quadri elettrici indipendenti per ogni singolo box
 - Gestione tramite tablet di ogni singolo box
 - **Volume di riempimento bagno per singolo tamburo: 350 l**
 - **Consumi specifici a partire da 10 l/kg dipendendo dal colore e tipo di lavorazione effettuata**
 - Elevato numero di ricircoli e reintegri di acqua pulita (fino a 3 volte per minuto)
 - Camera tamburo con bagno in pressione per una perfetta penetrazione nella fibra
 - Profilo sagomato per un aumento dell'effetto lavante (over-flow system)
 - Motorizzazione controllata da inverter
 - Controllo ottimizzato del tiro grazie a celle di carico montate su ogni rinvio
 - Grande compattezza, modularità e migliore robustezza
 - Ridotte dimensioni di ingombro
 - Gestione della linea con PLC, con software di ultima generazione TECOP Termoelettronica
- *Liquor flow in forced counterflow*
 - *High efficiency washing "star" drums*
 - *Water regeneration system*
 - *Channeled air in every washing box*
 - *Self-cleaning external filtering system, suitable for any kind of fiber and processing*
 - *Simplified access for routine maintenance*
 - *Integrated smart remote management (4.0)*
 - *Realtime machine data gathering on cloud for elaboration and preventive maintenance*
 - *Independent electrical panels for each box*
 - *Tablet management of each box*
 - ***Bath filling volume for single drum: 350 l***
 - ***Specific consumption from 10 l/kg depending the color and type of textile processing***
 - *Best washing effect thanks to various recirculation devices and clean-water inlets (up to 3 times per minute)*
 - *Pressurised chamber containing the drum, for a perfect penetration into the fibre*
 - *Shaped profile of the pressurised chamber for an more efficient washing effect (over-flow system)*
 - *Motors controlled by inverters*
 - *Optimised control of fabric draw, thanks to load-cells installed on each fabric transmission*
 - *Great compactness, modularity and better strength*
 - *Reduced dimensions*
 - *Line Management via PLC and latest-generation software TECOP Termoelettronica*



MODELS DATA

STARWASH-EVO può essere configurata per ogni tipo di lavorazioni ed esigenze richieste.

Il numero delle vasche e la loro altezza, potrà variare a seconda dal tipo di tessuto processato e dalla produzione richiesta.

Le più comuni sono indicate negli schemi sottostanti:

STARWASH-EVO can be configured for any type of processing and requirements.

The number of troughs and their height may vary depending on the type of fabric processed and the production required.

The most common ones are indicated in the schemes below:

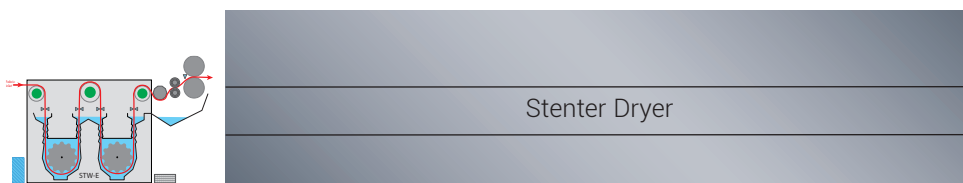

FAST SCOURING LINE

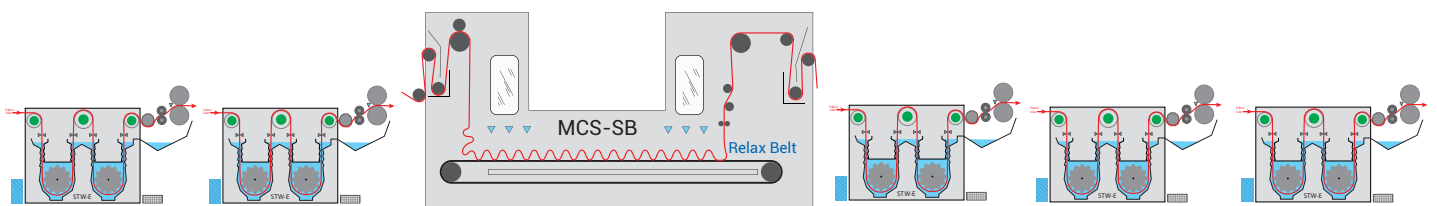

RELAX SCOURING LINE

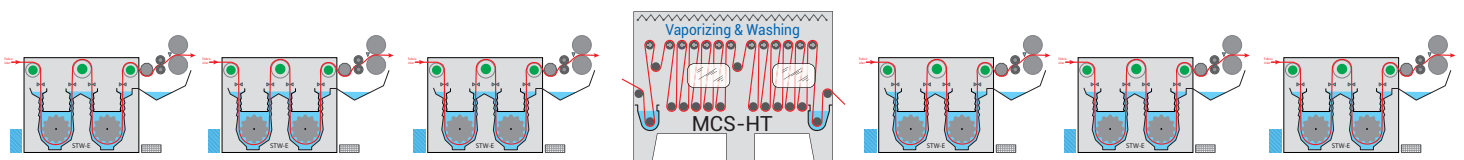

WASHING AND WOOL CRABBING

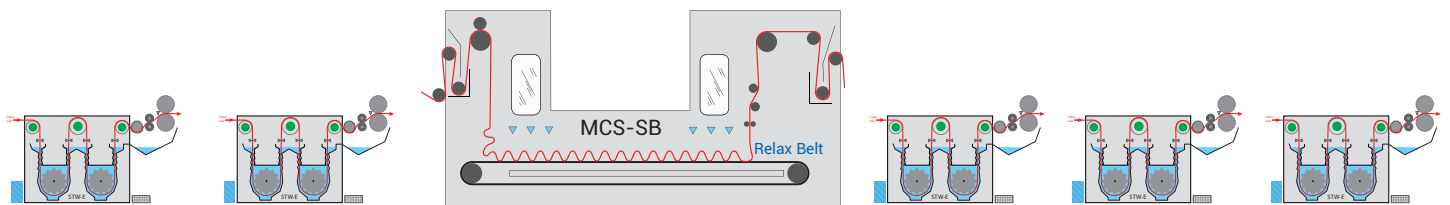

WASHING LINE WITH RELAX BELT

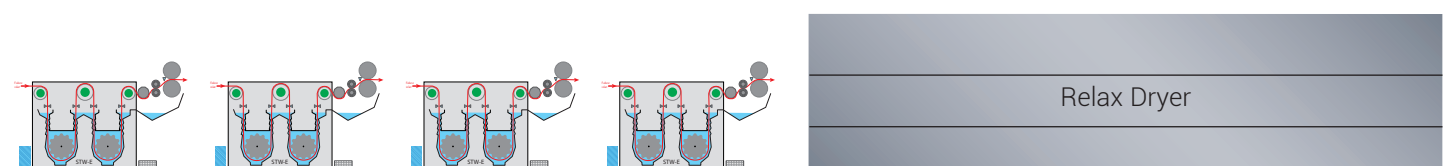

WASHING LINE WITH DRYER

ALL WASHING LINES ARE AUTOMATED WITH TEMOELETRONICA SOFTWARE AND CONTROLLERS.

CTRL-WASH

CTRL-WASH next gen Windows 10 IOT con schermo touch screen capacitivo e nuovo software di controllo TECOP il quale presenta un'interfaccia grafica interamente ridisegnata con sinottico dinamico in grafica vettoriale.

CTRL-WASH next gen windows 10 IOT with capacitive touch screen and new automation software TECOP bringing a completely new graphical interface, dynamic synoptic and vectorial graphics.



TABLET-10



Tablet 10" Rugged IP67 Windows 10 IOT, senza installazione di software aggiuntivo consente la connessione all'impianto per monitoraggio/utilizzo dell'impianto tramite Wifi, semplifica notevolmente tutte le interazioni con la macchina(marcia/arresto).

Tablet 10" Rugged IP67 Windows 10 IOT, without any further software it allows to access to the entire system for monitoring and handling machine through wifi connection.

CONT-DOSING Dosing of pure products and water control in a washing line

Il sistema CONT-DOSING è un sistema gestito da un PC in comunicazione con un PLC; può comandare fino a 8 pompe dosatrici e controllare fino a 8 ingressi d'acqua.

Le pompe dosatrici usate sono a pistone pneumatico a doppio effetto: la frequenza di comando è calcolata in modo da evitare repentine e variazioni della concentrazione del bagno.

The CONT-DOSING system is a system managed by a PC communicating with a PLC which can control up to 8 dosing pumps and 8 water inlets.

Installed dosing pumps are with pneumatic piston at double effect. Pump control frequency values are calculated so as to avoid sudden changes in the concentration of the bath.

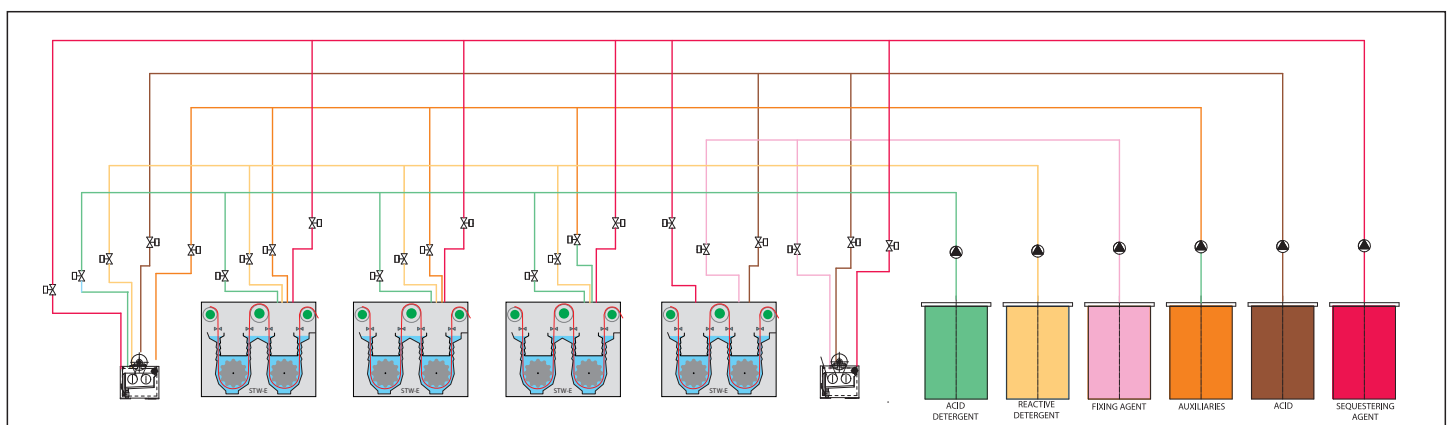

TEX-LINE 4.0 Software integrated for washing lines

- Gestione parametrizzazioni linea
- Gestione delle pianificazioni
- Controllo real time dati macchina
- Database degli articoli

- Parametrization Handling
- Batches Handling
- Real time machines supervising
- Fabrics database

FEEL THE POWER OF WATER

DYEING & FINISHING MACHINERY



MCS
Bergamo | Italy | mcstextile.it

